



**SYNTHESI**

**Tecnologia evoluta a servizio dell'uomo**



**ATLANTA**  
S T R E T C H

---

# SYNTHESI

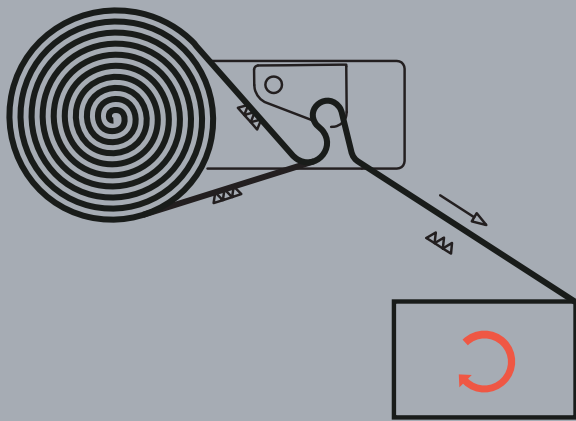

**Parametri facilmente regolabili tramite pannello.**

- Velocità di rotazione tavola.
- Velocità salita e discesa carrello regolabili separatamente.
- Programmazione separata giri alti e bassi.
- Fotocellula lettura altezza pallet.
- Avvolgimento con esclusione fotocellula (Altimetro)
- Ciclo salita / salita e discesa.
- Ciclo mettifoglio.
- Cicli manuali:  
Rotazione tavola,  
Salita e discesa carrello portabobina.

**Parameters easily adjustable from the panel.**

- Table rotation speed.
- Independently adjustable upwards and downwards carriage speeds.
- Separate programming for high and low rpm.
- Pallet height photoelectric cell reading.
- Wrapping cycles with altimeter (Without photocell).
- Ascent / Ascent and Descent cycle.
- Sheet placement cycle.
- Manual cycles:  
Table rotation,  
Roll carriage ascent and descent.

**Paramètres ajustables au pupitre**

- Vitesse de rotation de la table.
- Vitesse montée et descente chariot réglable separement.
- Tours droits haut et bas séparés.
- Débordement supérieur du film.
- Cycle banderolage avec altimetre (sans photocellule).
- Cycle montée et descente.
- Cycle montée et descente seule.

- Cycle dépose de coiffe.
- Cycles manuels:  
Rotation table  
Montée/arrêt du chariot  
Descente /arrêt du chariot.

**Einstellbare Parameter von Bedienungstafel:**

- Stufenlos regelbare Drehtellergeschwindigkeit.
- Regelbare Hubschlittengeschwindigkeiten. Auf- und Abwärts getrennt einstellbar.
- Einstellbare Anzahl für Fuß- und Kopfwicklungen.
- Fotozelle zur selbständigen Höhenabfrage.
- Wickelprogramme mit Höhenmesser (Ohne Fotozelle).
- Kreuzspiral und Spiral.
- Regendichtprogramm
- Manueller Zyklusablauf:  
Drehtellerdrehung.  
Hubschlitzen Auf- und Abwärts.

**Parámetros fácilmente regulables mediante panel.**

- Velocidad de rotacion mesa.
- Velocidad subida y bajada carro regulable por separado.
- Programacion separada de vueltas altas y baja.
- Fotocelula lectura altura palet.
- Envolvimiento con exclusión de la fotocelula (Altimetro)
- Ciclo subida / subida y bajadacesa.
- Ciclo metto metefolio.

**Dati Tecnici****SYNTHESE****SYNTHESE TP**

|                                        |                          |                          |
|----------------------------------------|--------------------------|--------------------------|
| Potenza totale installata              | 0.85 Kw                  | 0.85 Kw                  |
| Tensione alimentazione standard        | 230V monofase - 50/60 Hz | 230V monofase - 50/60 Hz |
| Protezione impianto elettrico e motori | IP 54                    | IP 54                    |
| Dimensione max pallet                  | 800 x 1200 mm            | 1000 x 1200 mm           |
| Altezza std pallet                     | 2200 mm                  | 2200 mm                  |
| Portata max                            | 1500 Kg                  | 1200 Kg                  |
| Diametro tavola                        | 1500 mm                  | 1640 mm                  |

**Technical Characteristics****SYNTHESE****SYNTHESE TP**

|                                         |                            |                            |
|-----------------------------------------|----------------------------|----------------------------|
| Total installed power                   | 0.85 Kw                    | 0.85 Kw                    |
| Standard input voltage                  | 230V mono-phase - 50/60 Hz | 230V mono-phase - 50/60 Hz |
| Electrical system and motors protection | IP 54                      | IP 54                      |
| Max pallet dimensions                   | 800 x 1200 mm              | 1000 x 1200 mm             |
| Standard pallet height                  | 2200 mm                    | 2200 mm                    |
| Max capacity                            | 1500 Kg                    | 1200 Kg                    |
| Table diameter                          | 1500 mm                    | 1640 mm                    |

**Données Techniques****SYNTHESE****SYNTHESE TP**

|                                               |                            |                            |
|-----------------------------------------------|----------------------------|----------------------------|
| Puissance totale installée                    | 0.85 Kw                    | 0.85 Kw                    |
| Tension alimentation standard                 | 230V mono-phase - 50/60 Hz | 230V mono-phase - 50/60 Hz |
| Protection installation électrique et moteurs | IP 54                      | IP 54                      |
| Dimensions maximum palette                    | 800 x 1200 mm              | 1000 x 1200 mm             |
| Hauteur standard palette                      | 2200 mm                    | 2200 mm                    |
| Portée maximum                                | 1500 Kg                    | 1200 Kg                    |
| Diamètre de la table                          | 1500 mm                    | 1640 mm                    |

**Technische Daten****SYNTHESE****SYNTHESE TP**

|                                    |                            |                            |
|------------------------------------|----------------------------|----------------------------|
| Gesamte Leistung                   | 0.85 Kw                    | 0.85 Kw                    |
| Anschluss-Spannung                 | 230V mono-phase - 50/60 Hz | 230V mono-phase - 50/60 Hz |
| Elektroanlage und Motore Schutzart | IP 54                      | IP 54                      |
| Max. Palettenabmessung             | 800 x 1200 mm              | 1000 x 1200 mm             |
| Max. Standard Wickelhöhe           | 2200 mm                    | 2200 mm                    |
| Max. Ladungsgewicht                | 1500 Kg                    | 1200 Kg                    |
| Drehteller Durchmesser             | 1500 mm                    | 1640 mm                    |

**Datos Técnicos****SYNTHESE****SYNTHESE TP**

|                                        |                            |                            |
|----------------------------------------|----------------------------|----------------------------|
| Potencia total instalada               | 0.85 Kw                    | 0.85 Kw                    |
| Tension de alimentacion estandar       | 230V mono-phase - 50/60 Hz | 230V mono-phase - 50/60 Hz |
| Proteccion montaje electrico y motores | IP 54                      | IP 54                      |
| Dimension max palet                    | 800 x 1200 mm              | 1000 x 1200 mm             |
| Altura estandar palet                  | 2200 mm                    | 2200 mm                    |
| Peso max                               | 1500 Kg                    | 1200 Kg                    |
| Diametro mesa                          | 1500 mm                    | 1640 mm                    |

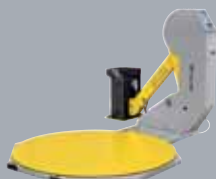
**SFERA****MYTHO****MYTHO-A****REVOLUTION****OMEGA**

**ATLANTA**  
S T R E T C H

ATLANTA STRETCH S.p.A  
Via Chiesa di Camerano, 30  
47824 Poggio Berni (Rimini)  
ITALIA

Tel. +39 0541 627145  
Fax +39 0541 627220  
[www.atlantastretch.com](http://www.atlantastretch.com)  
[sales@atlantastretch.com](mailto:sales@atlantastretch.com)

Atlanta Deutschland GmbH  
Atlanta Stretch Sweden AB  
Atlanta Packaging SA - Spain  
Atlanta Packaging Ltd - UK  
Atlanta France Sarl  
Atlanta Packaging Systems Australasia