



GEM 50

LATEST GENERATION

GEM 50

[It]
DESCRIZIONE

Nastratrice per scatole a formato fisso.

La serie GEM caratterizzata da robustezza, semplicità e minima manutenzione a costi di gestione nella misura più ridotta.

[En]
DESCRIPTION

Uniform case sealer.

The GEM series featured by strength, simplicity and minimal maintenance at the lowest cost of ownership.

[Fr]
DESCRIPTION

Machine a fermer les caisses americaines monofomat.

La série GEM caractérisée par la robustesse, la simplicité et un entretien minimal pour des coûts de fonctionnement très réduits.

[De]
BESCHREIBUNG

Kartonschachtel-verschliessmaschine für gleichbleibende formate.

Die GEM-Serie zeichnet sich durch Robustheit, Einfachheit und minimale Wartung bei geringsten Betriebskosten aus.

[Es]
DESCRIPCIÓN

Precintadora para cajas de formato fijo.

La serie GEM se caracteriza por su robustez, simplicidad y mantenimiento mínimo con costes de funcionamiento más bajos.

DATI TECNICI:

TECHNICAL DATA:

DONNÉES TECHNIQUES:

TECHNISCHE DATEN:

FICHA TÉCNICA:

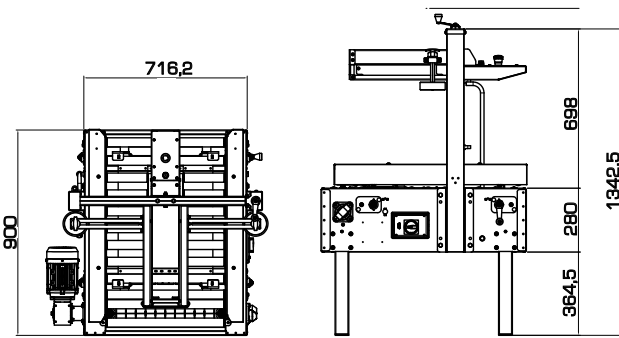

misure/measures/mesures/maßnahmen/medidas: mm

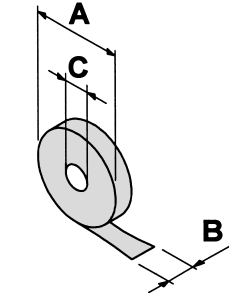

| | |
|---|-------------------|
| A | MAX 360 mm (14") |
| B | 25+75 mm (1"+ 3") |
| C | 76 mm (3") |

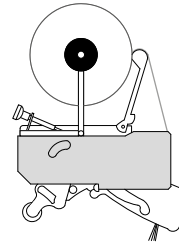

- Teste Nastranti:
- Taping Heads:
- Têtes de pose:
- Klebeköpfe:
- Cabezal de precinto:

T21-T21,5-T22-T23
T32-T33
TH22-TH23

- Gambe con piedino fisso
- Legs with fixed foot
- Pieds à base fixe
- Standbeine mit fixem Fuß
- Patas con pie fijo

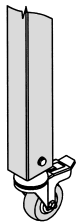
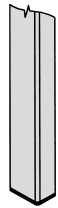

- OPTIONAL:
- Gambe con ruote
 - Legs with wheels
 - Pieds à roulettes
 - Standbeine mit Rädern
 - Patas con ruedas

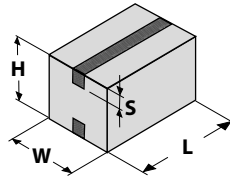

| | MIN | MAX |
|---|--------|--------|
| L | 150 mm | ∞ |
| W | 100 mm | 500 mm |
| H | 100 mm | 500 mm |
| S | 25 mm | 75 mm |

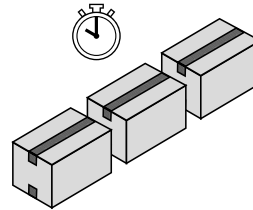

- Produzione media:
- Average production:
- Production moyenne: 1000 scatole/h
- Durchschnittliche Produktion:
- Producción promedio:

- Velocità di trasferimento scatola:
- Box transfer speed:
- Vitesse de transfert de la boîte: ~22 m²/min
- Transportgeschwindigkeit der Kartons:
- Velocidad de desplazamiento caja:



- Alimentazione:
- Power supply: $\equiv 3 / \perp$
- Alimentation:
- Speisung:
- Alimentación:

- Potenza installata:
- Installed power: 0,25 kW
- Puissance installée:
- Eingerichtete Leistung:
- Potencia instalada:

- Protezione elettrica:
- Electrical protection: IP54
- Protection électrique:
- Stromschutz:
- Protección eléctrica:



- Temperatura di utilizzo:
- Temperature of use:
- Température d'utilisation:
- Betriebstemperatur:
- Temperatura de uso:

| | MIN | MAX |
|----|-----|-----|
| °C | +5 | +35 |
| °F | +41 | +95 |

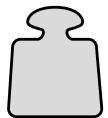

- Peso:
- Weight: 90 Kg
- Poids:
- Gewicht:
- Peso:

Distributed by

COMARME
SEALING

COMARME S.r.l. a socio unico
sede operativa (factory)
Quartiere Mirabella snc, 20081 Abbiategrasso (MI) - ITALY
Tel. +39 02 9422002 - Fax +39 02 9422096
e-mail: info@comarmesrl.com - website: www.comarmesrl.com