

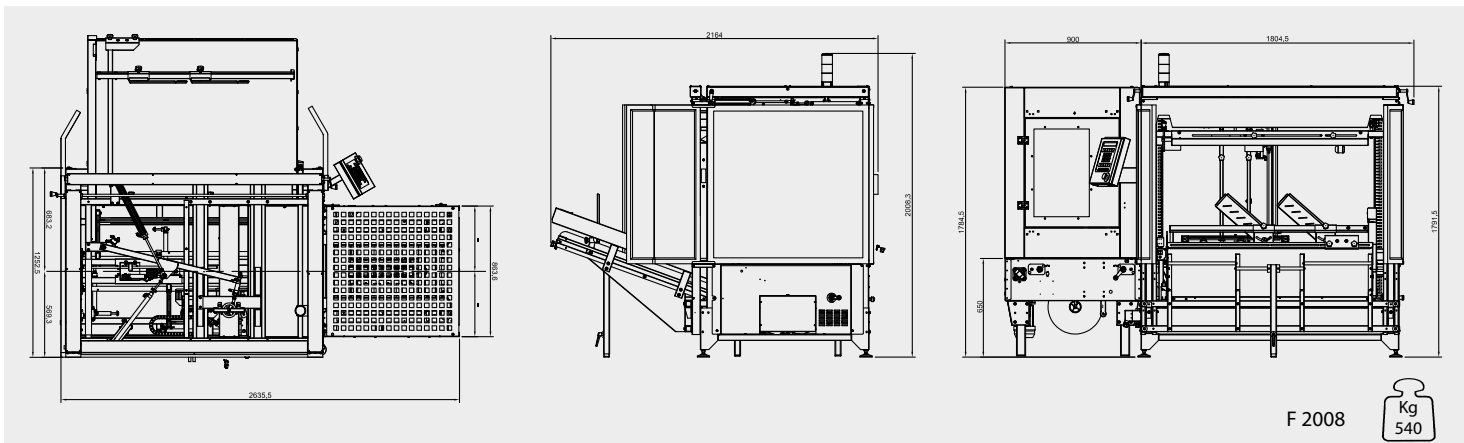

## F2008

- FORMATORE AUTOMATICO DI SCATOLE
- FORMEUSE AUTOMATIQUE DE CARTONS
- FORMADORA AUTOMÁTICA DE CAJAS
- AUTOMATIC CARTON ERECTING MACHINE
- AUTOMATISCHER KARTONAUFRICHTER



F 2008

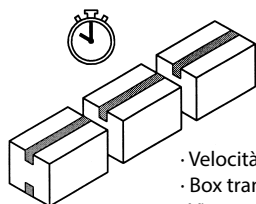

- Produzione media: 720 scatole/ora
- Production moyenne: 720 boîtes/heure
- Producción promedio: 720 cajas/hora
- Average production: 720 boxes/hour
- Durchschnittliche Produktion: 720 Kartons/Std
- Velocità di trasferimento scatola: ~22 mt/min
- Box transfer speed: ~22 mt/min
- Vitesse de transfert de la boîte: ~22 mt/min
- Transportgeschwindigkeit der Kartons: ~22 mt/min
- Velocidad de desplazamiento caja: ~22 mt/min

- Alimentazione pneumatica
- Pneumatic power supply
- Alimentation pneumatique
- Druckluftspeisung
- Alimentación neumática

6 bar

- Consumo aria per ciclo scatola
- Air consumption cycle box
- Consommation d'air par cycle boîtes
- Luftverbrauch pro Kartonzyklus
- Consumo de aire por ciclo caja

22 nl

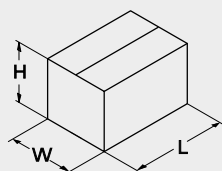

F 2008

	MIN	MAX
L	220 mm	800 mm
W	100 mm	500 mm
H	100 mm	500 mm

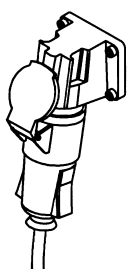

- Alimentazione: 3Ph+PE a richiesta altre alimentazioni
- Power supply: 3Ph+PE other power supplies on demand
- Alimentation: 3Ph+PE autres alimentations sur demande
- Speisung: 3Ph+PE andere lieferungen auf anfrage
- Alimentación: 3Ph+PE otros suministros a petición
- Potenza installata: 1 kW
- Installed power: 1 kW
- Puissance installée: 1 kW
- Eingerichtete Leistung: 1 kW
- Potencia instalada: 1 kW
- Protezione elettrica: IP54
- Electrical protection: IP54
- Protection électrique: IP54
- Stromschutz: IP54
- Protección eléctrica: IP54

🇮🇹 OPTIONALS:

- PLC con pannello touch screen
- Ruote con freno
- Magazzino motorizzato con capacità scatole fino a 300 sc.modello CAR 2002

🇬🇧 OPTIONALS:

- Control panel with Siemens / Omron / Schneider / Allen-Bradley PLC
- Caster wheels for min working table height 750 mm
- CAR 2002 Motorised box loader with capacity of 300 boxes

🇫🇷 OPTIONALS:

- Panneau de commandes automate PLC
- Roues avec frein pour hauteur de travail 750 mm
- Magasin de caisses vides CAR 2002 avec une capacité de 300 caisses

🇩🇪 OPTIONALS:

- SPS mit Touch-Screen-Panel
- Räder mit Feststellbremse
- Motorisiertes Magazin für bis zu 300 Faltkartons Typ CAR 2002

🇪🇸 OPCIONALES:

- PLC con panel de pantalla táctil
- Ruedas con freno
- Almacén motorizado con capacidad hasta 300 Mod. CAR 2002

- Sistema vuoto Venturi: 25m3/h 700mm HG
- Venturi vacuum unit: 25m3/h 700mm HG
- Groupe de vide Venturi: 25m3/h 700mm HG
- Vakuum Venturi Gruppe: 25m3/h 700mm HG
- Equipo de vacío Venturi : 25m3/h 700mm HG

- Capacità magazzino: 110 scatole
- Box loader unit capacity: 110 boxes
- Capacité magasin (boîtes): 110 boîtes
- Kartonstapel-Einheit Ladungskapazität: 110 Kartons
- Capacidad almacen: 110 cajas

- 🇮🇹 Nastratrice GEM B52 per chiusura falde inferiori scatola
- 🇬🇧 Bottom case sealer GEM B52 model to bottom flaps closing
- 🇫🇷 Scotcheuse de fond des caisses GEM B52
- 🇩🇪 Unterbodenverschließmaschine GEM B52 Model
- 🇪🇸 Precintadora de fondos de cajas GEM B52



Distributed by



COMARME S.r.l. a socio unico  
sede operativa (factory)

Quartiere Mirabella snc, 20081 Abbiategrasso (MI) - ITALY  
Tel. +39 02 9422002 - Fax +39 02 9422096

e-mail: info@comarmesrl.com - website: www.comarmesrl.com